

**IATA ULD code: PGA/PGF Q7**  
 Universal general-purpose flat pallet for lower holds and main decks.

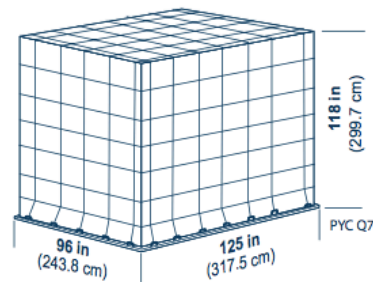

**IATA ULD code: PYB Q7**  
 Universal general-purpose flat pallet for lower holds and main decks.

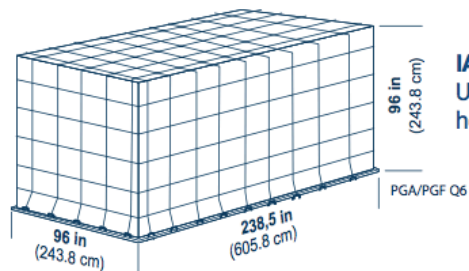

**IATA ULD code: PGA/PGF Q6**  
 Universal general-purpose flat pallet for lower holds and main decks.

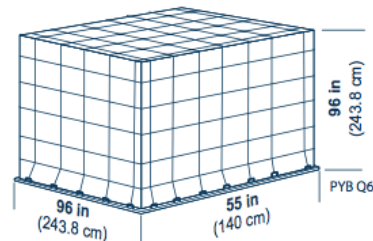

**IATA ULD code: PYB Q6**  
 Universal general-purpose flat pallet for lower holds and main decks.

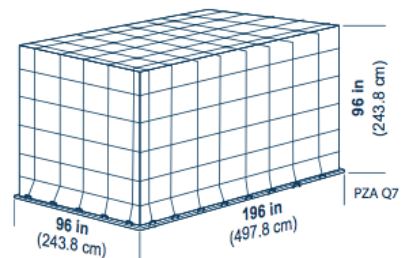

**IATA ULD code: PZA Q7**  
 Universal general-purpose flat pallet for lower holds and main decks.

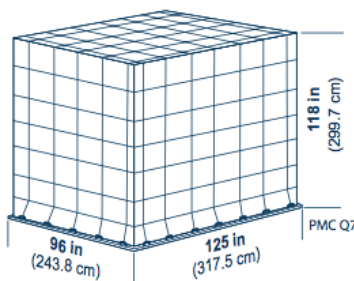

**IATA ULD code: PMC Q7**  
 Universal general-purpose flat pallet for lower holds and main decks.  
 Tare weight: 120 kg (265 lb)  
 Volume: H 299.7 cm (118 in), 21.2 m<sup>3</sup> (750 ft<sup>3</sup>)

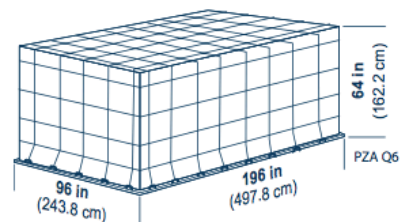

**IATA ULD code: PZA Q6**  
 Universal general-purpose flat pallet for lower holds and main decks.

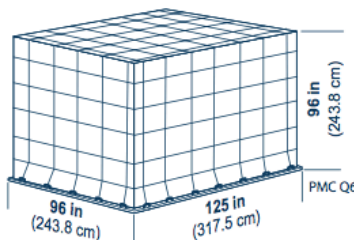

**IATA ULD code: PMC Q6**  
 Universal general-purpose flat pallet for lower holds and main decks.  
 Tare weight: 120 kg (265 lb)  
 Volume: H 243.8 cm (96 in), 17.0 m<sup>3</sup> (600 ft<sup>3</sup>)

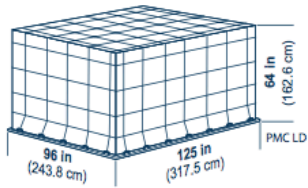

**IATA ULD code: PMC LD**  
 Universal general-purpose flat pallet for lower holds and main decks.  
 Tare weight: 120 kg (265 lb)  
 Volume: H 162.6 cm (64 in), 11.5 m<sup>3</sup> (407 ft<sup>3</sup>)

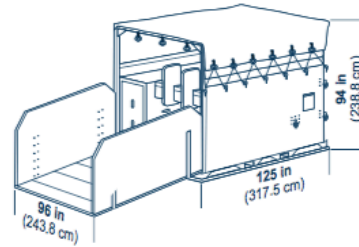

**IATA ULD code: HMA horse box on P6P pallet base**  
 P6P base with IATA-specified horse box stalls attached.  
 Available with canvas top or solid roof. Some further modified versions available with position for escort.  
 Maximum gross weight: 3,500 kg (7,716 lb)  
 Tare weight: 1,310 kg (2,888 lb)

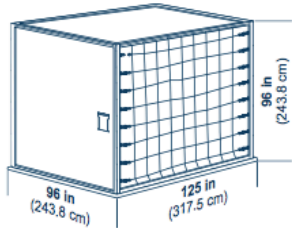

**ULD code: AMA rectangular container on P6P base**  
 Main-deck container. Door is canvas with built-in net door straps.  
 Maximum gross weight: 6,804 kg (15,000 lb)  
 Tare weight: 350 kg (772 lb),

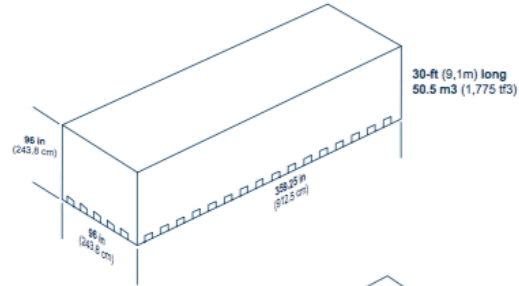

**747F nose cargo door only**

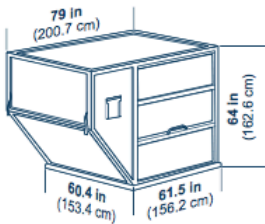

**IATA ULD code: AKE contoured container**  
 Half-width lower hold container with one angled side. Door is either canvas or solid.  
 Door opening: 58 x 61-in (147 x 155-cm)  
 Maximum gross weight: 1,588 kg (3,500 lb)  
 Tare weight: 82 kg (181 lb)  
 AS1825 volume: 4.5 m<sup>3</sup> (159 ft<sup>3</sup>)

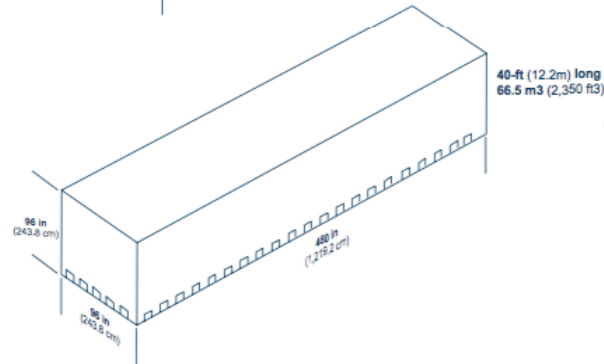

**747F nose cargo door only**

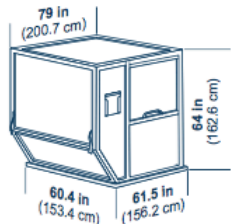

**IATA ULD code: RKN contoured cool container**  
 Half-width lower hold insulated container with one angled end. Door is solid. Most examples are forkable.  
 Door opening: 54 x 55-in (137 x 140-cm)  
 Maximum gross weight: 1,588 kg (3,500 lb)  
 Tare weight: 210 kg (463 lb)

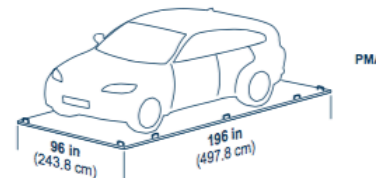

**IATA ULD code: PRA 16-ft flat pallet**  
 Description: Main-deck pallet with special moulding for car rack attachments.